

60 ...400 l/min	Supape de sens unic DN 10 20 32	Fc - 11
315 bar		

GENERALITATI

Supapele de sens unic asigura inchiderea etansa in sensul B->A prin supapa conica pe scaun circular.

Revenirea si mentinerea pe scaun cu arc de compresiune.

Suprafetele de montaj pe placa conform ISO 5781.

CARACTERISTICI TEHNICE

GENERALE

Pozitia de montaj : indiferenta

Sensul de curgere

A->B liber

B->A blocat

Temperatura mediului ambiant : -20°C.....+50°C

HIDRAULICE

Presiune nominala : 315 bar

Presiunea de deschidere: Dn 10: 0,8 bar; Dn 20: 0,4 bar; Dn 32:0,4 bar

Debitul nominal, la

$\Delta p = 1 \text{ bar} + \text{presiunea de deschidere: Dn10: 30l/min; Dn 20: 80l/min; Dn 32: 200l/min}$

Fluid :

Tipul fluidului : ulei mineral aditivat .

Domeniul de vascozitate : 10 ...500 cSt

Domeniul de temperatura : -20°C.....+80°C

Filtrare: 25...30 um

CURBE CARACTERISTICE

Pierdere de presiune in functie de debit $p=f(Q)$

Dn 10

$\nu = 35 \text{ cSt}$

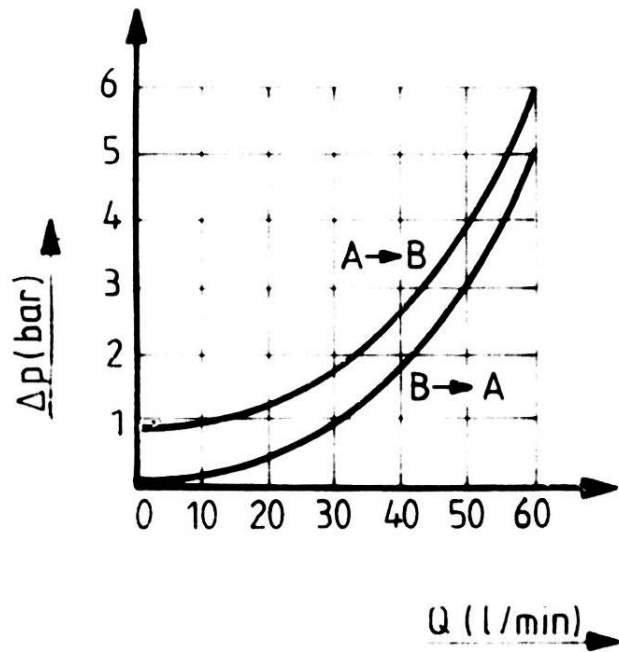

Fig. 1

Dn 20

$\nu = 35 \text{ cSt}$

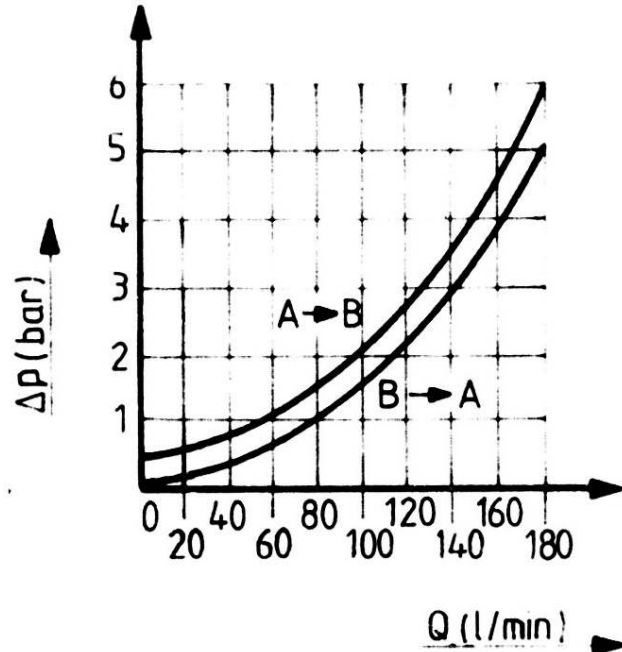

Fig. 2

Dn 32

$\nu = 35 \text{ cSt}$

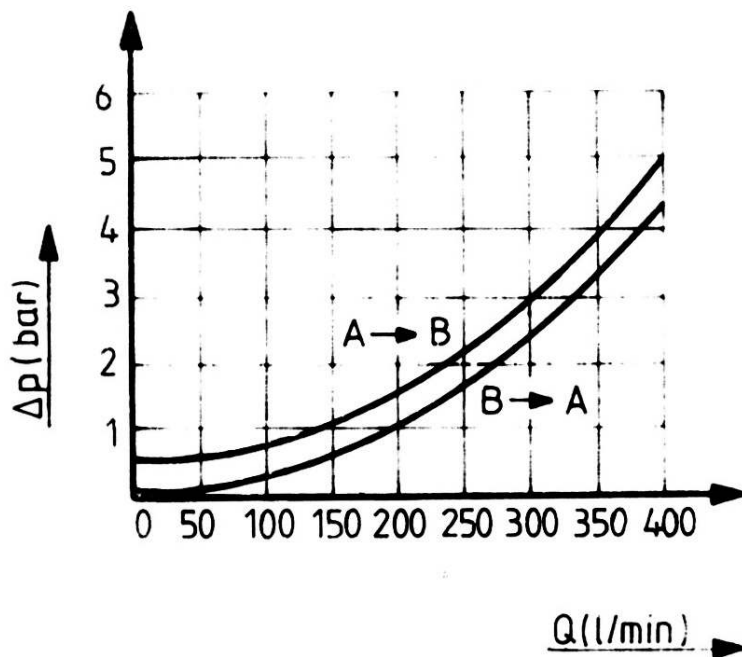

Fig. 3

DIMENSIUNI

Dn 10

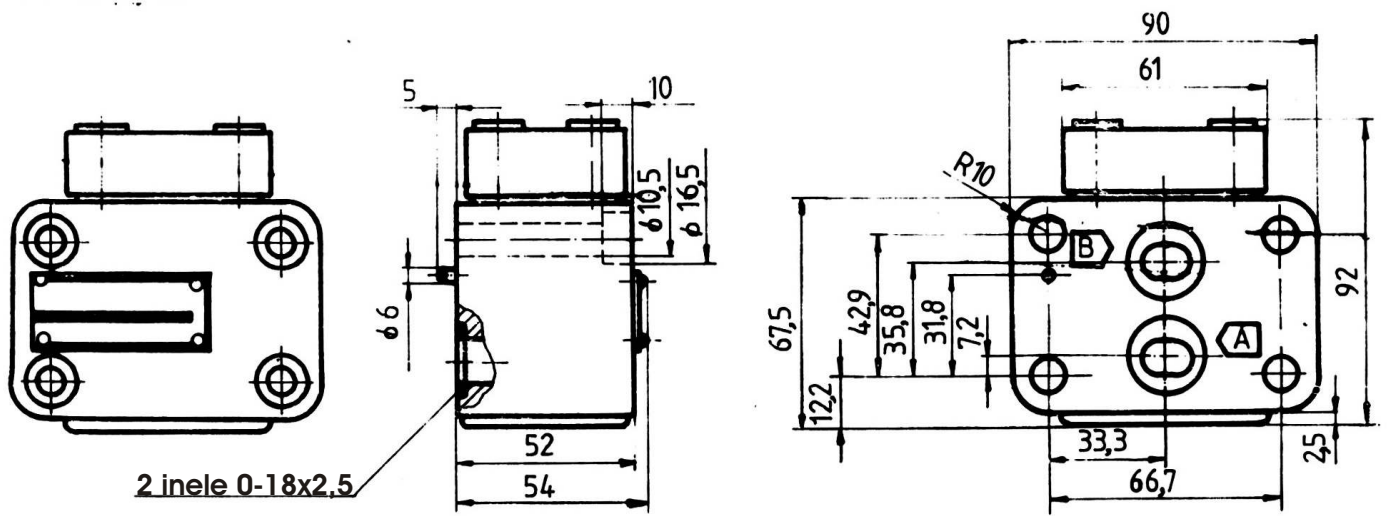

Fig. 4

Masa: 2,400 Kg

Dn 20

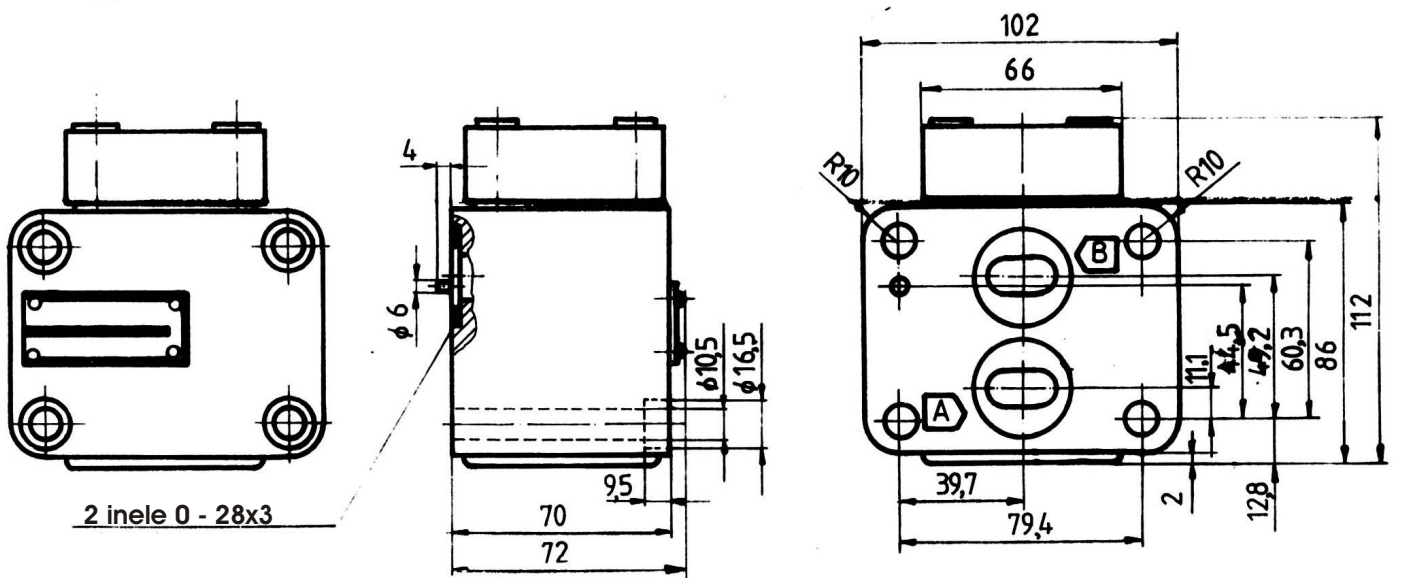

Fig. 5

Masa: 4,400 Kg

Dn 32

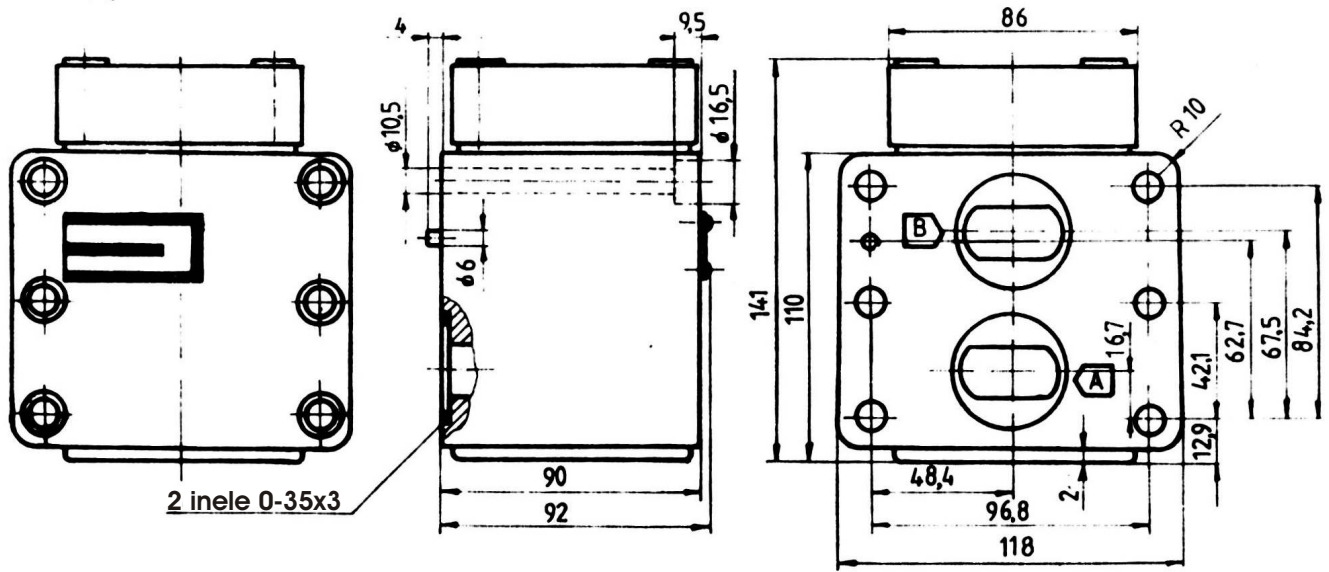

Fig. 6

Masa 8,800 Kg

PLACI DE BAZA

Dn 10

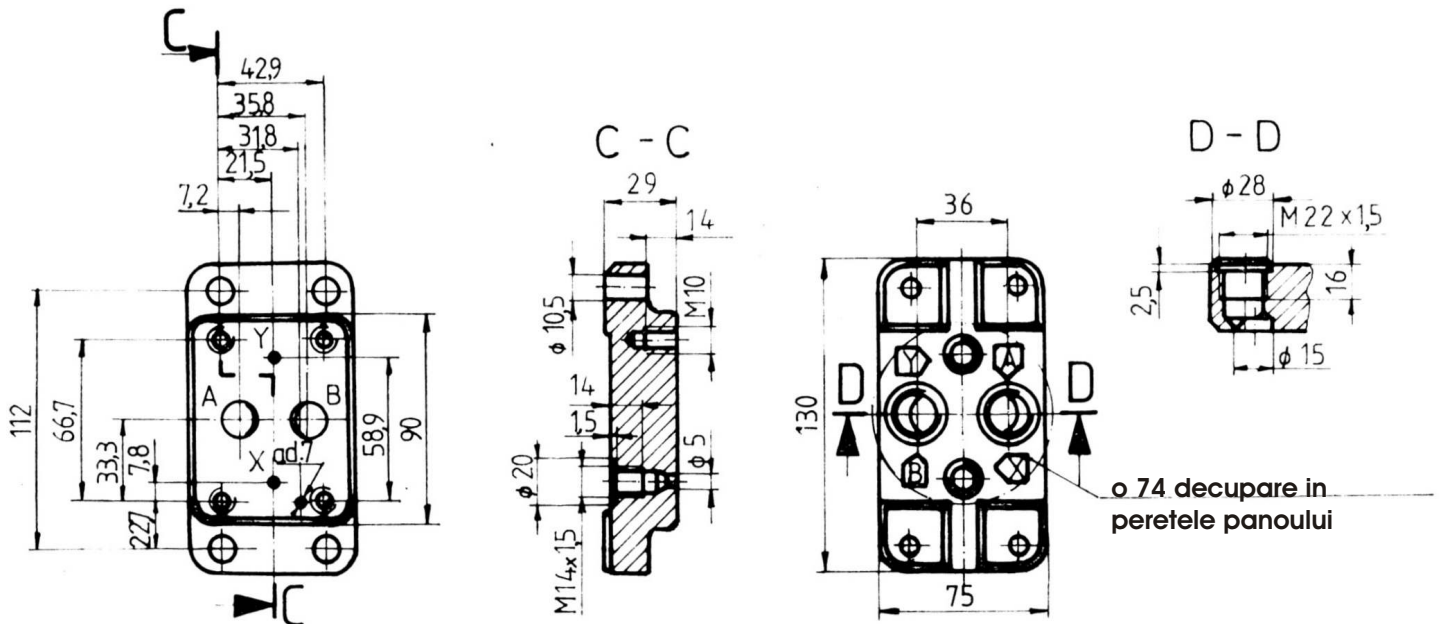

Fig. 7

Dn 20

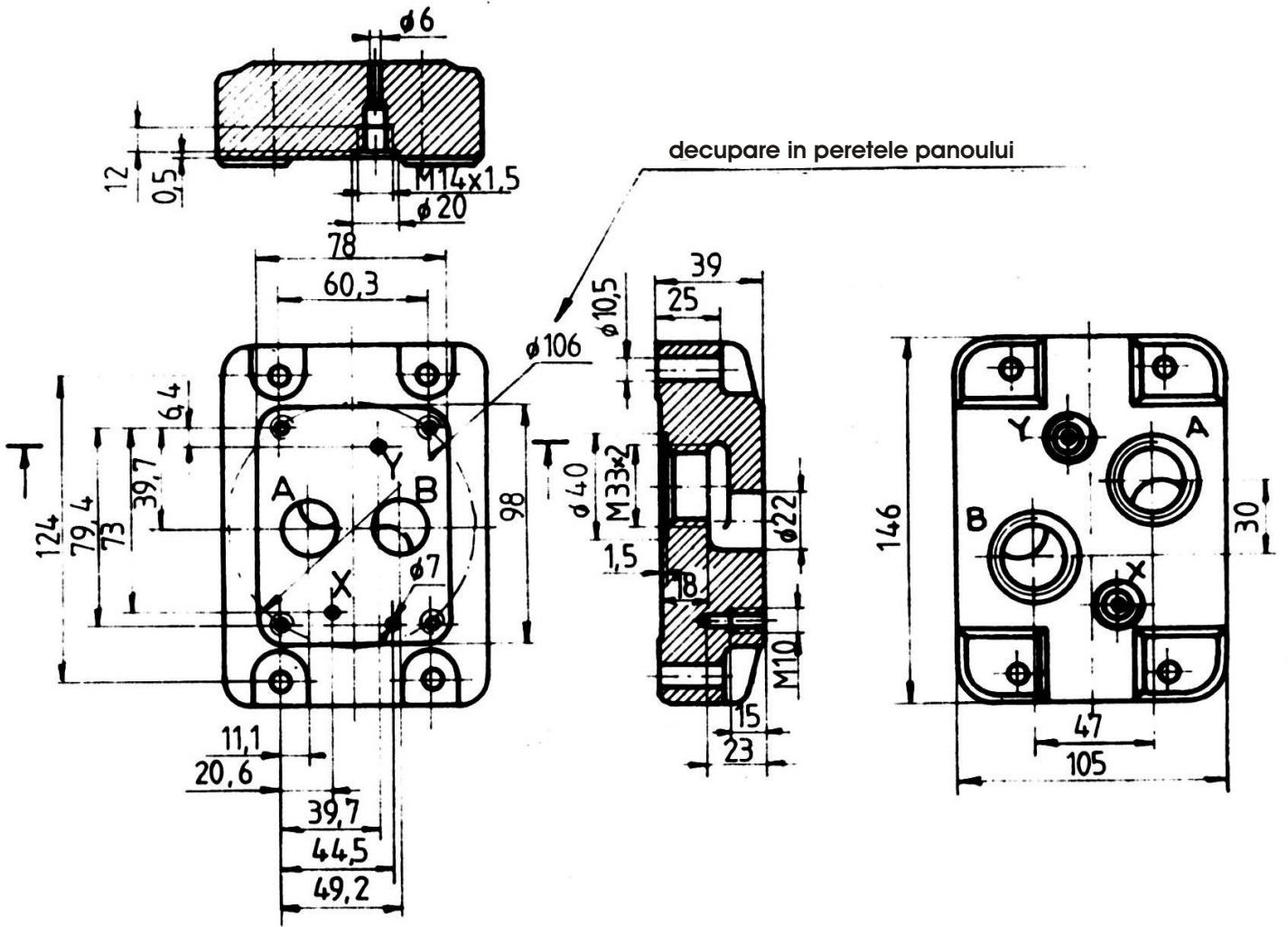

Fig. 8

Dn 32

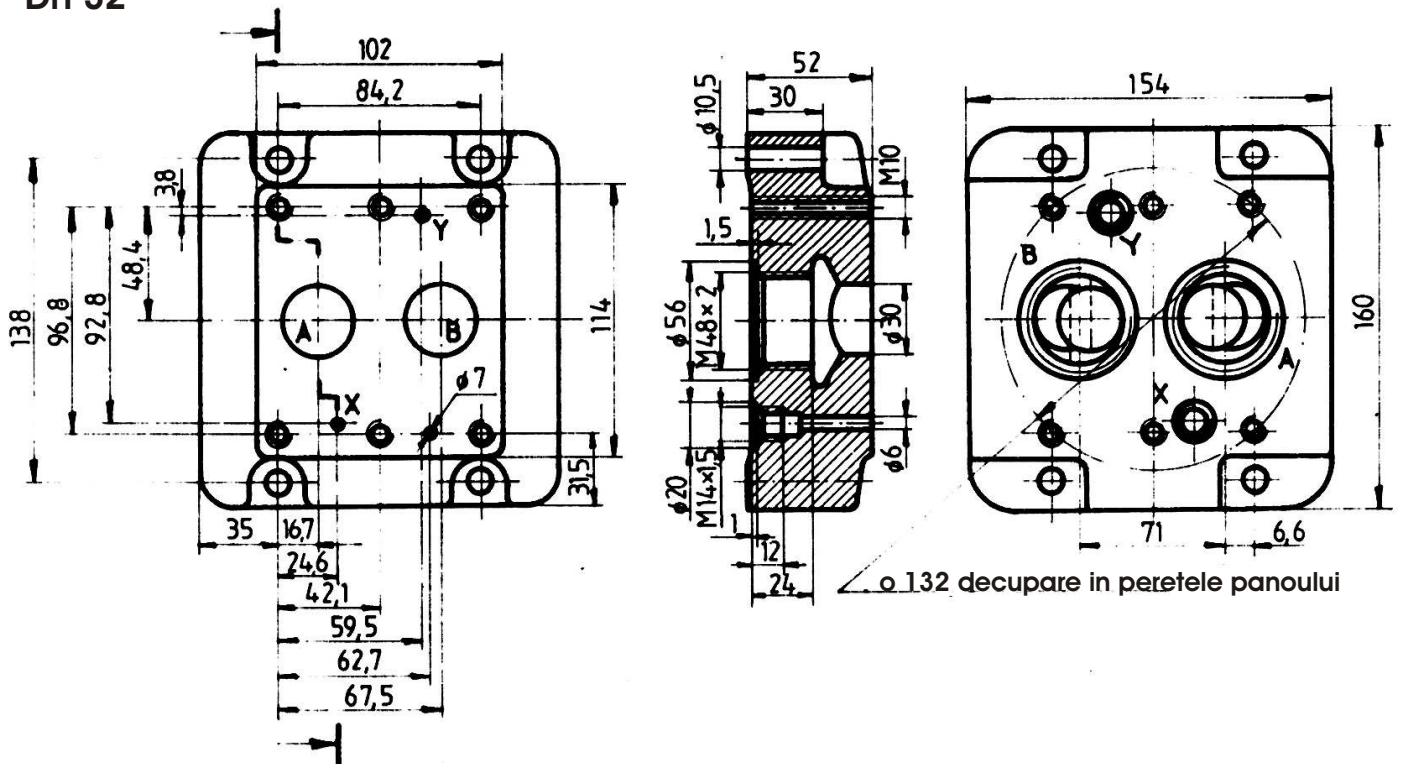

Fig. 9

Dn	Cod de comandă	Șuruburi de fixare	Moment de strângere (daNm)	Buc/ans.	Masa
10	PBS 10-1	M 10×55 STAS 5144-80 gr. 10.9	5 +1,3	4	1,300
20	PBS 20-1	M 10×75 STAS 5144-80 gr. 10.9	5 +1,3	4	3,400
32	PBS 32-1	M 10×100 STAS 5144-80 gr. 10.9	5 +1,3	6	5,000

INDICATII DE MONTAJ

Supapele se pot monta pe placi de baza proprii sau pe alte placi si blocuri cu circuite hidraulice.

In cazul montarii supapei pe alte placi decat cea de baza, se vor respecta urmatoarele:

- oglinda internationala de legatura conf. fig. 7, 8, si 9
- abaterea cotelor de legatura si montaj: $\pm 0,1$ mm
- abaterea diametrelor maxime ale gaurilor functionale: $\pm 0,25$ mm
- abaterea la planeitate a suprafetei de asezare: 0,01/100 mm

COD DE COMANDA

1 2 3 - 4 - /5*

* Pentru varianta climatizata se adauga la sfarsitul codului /T1 sau T2

1. SU-Supapa de sens unic
2. P-Montaj pe placa
3. Dimensiunea nominala 10, 20, 32
4. Presiunea de deschidere 1-<1 bar
5. O-Seria de fabricatie.