

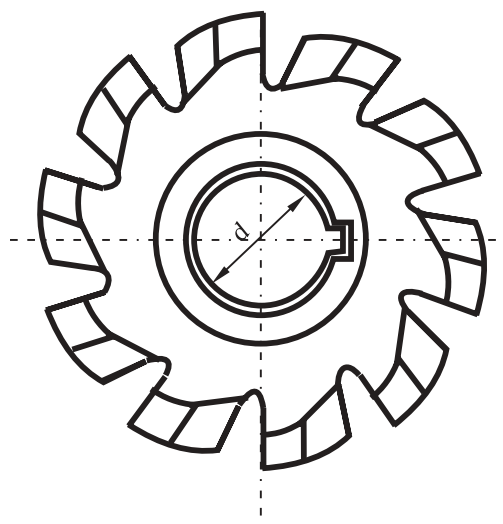

Freze melc pentru roți de lant Hobbing cutters for the sprocket wheels

STAS 8846-82

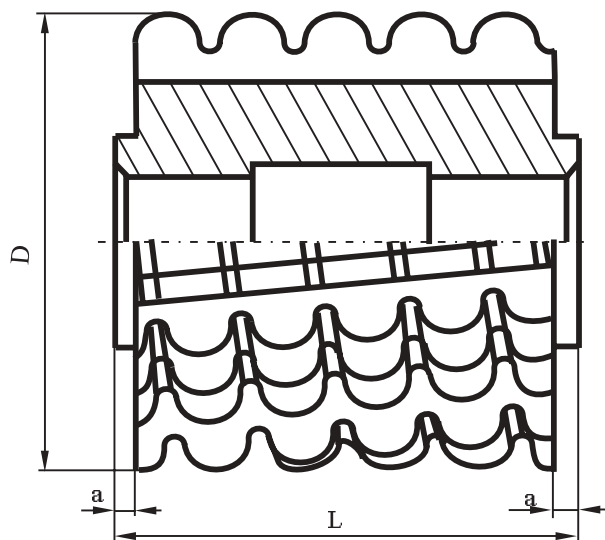

Lantul STAS 5174-66
chain

pasul p pitch	rola d1 roll	D mm	L mm	d mm	Nr. de dinti No. of teeth	Pret ()
1	2	3	4	5	6	7
8.00	6.00	63	45	27	12	
9.525	5.35	80	50	27	12	
12.70	7.95	80	60	27	12	
12.70	8.51	80	60	27	12	
15.875	10.16	80	70	27	12	
19.05	11.91	100	85	32	10	
19.05	12.07	100	85	32	10	
25.40	15.88	112	100	32	10	
31.75	19.05	112	130	32	10	
38.10	22.23	125	155	32	10	
38.10	25.40	140	155	40	10	
44.45	25.40	140	155	40	10	
44.45	27.94	160	180	40	9	
50.80	28.58	160	210	40	8	
50.80	29.21	160	210	40	8	
63.50	39.80	200	235	50	8	
76.20	47.63	224	300	50	8	