

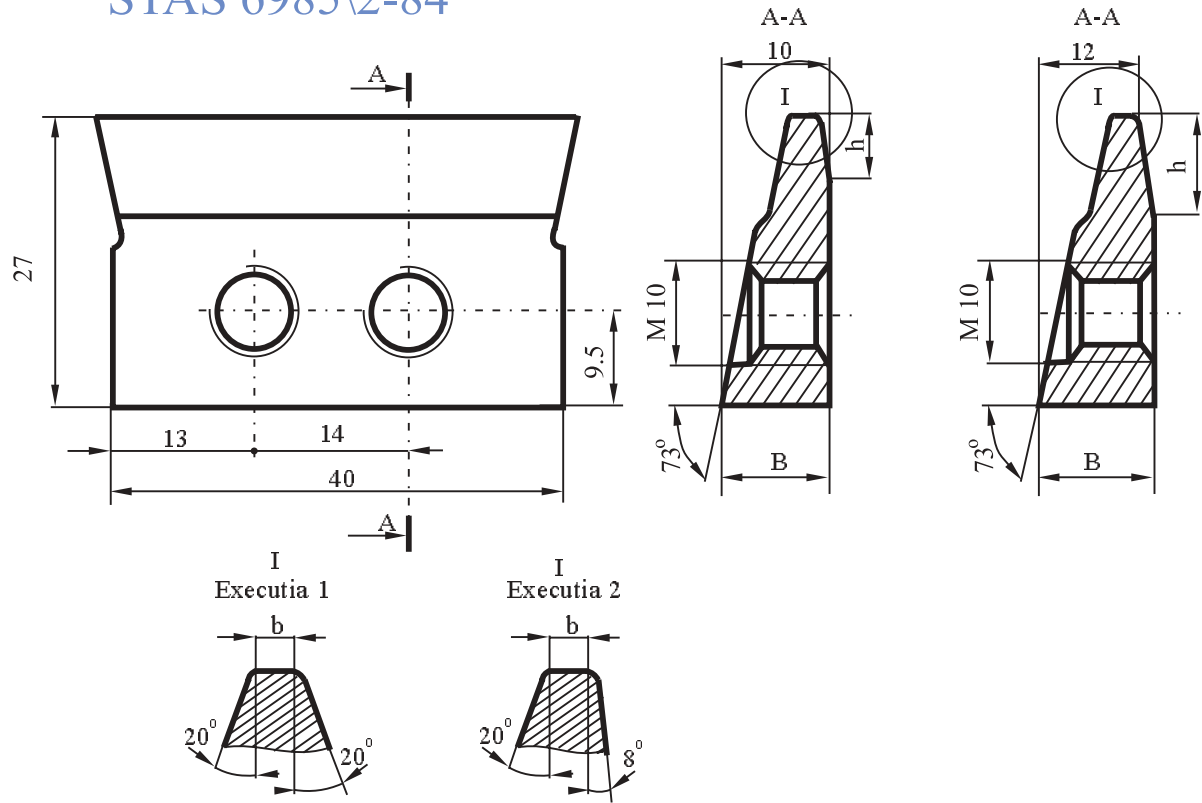

Cutite de rabotat roți dintate conice tip I

Tapered gear planing tools I type

STAS 6985\2-84



| Modul mm | Executia 1 | | Executia 2 | | b mm | Pret () |
|--------------|------------|---------|------------|---------|---------|----------|
| | B mm | h mm | B mm | h mm | | |
| 1 | 2 | 3 | 4 | 5 | 6 | 7 |
| 0.3...0.35 | 10.36 | 1 | 12.18 | 2 | 0.12 | |
| 0.4...0.45 | 10.44 | 1.2 | 12.22 | 2.2 | 0.16 | |
| 0.5...0.55 | 10.51 | 1.4 | 12.26 | 2.5 | 0.20 | |
| 0.6...0.7 | 10.66 | 1.8 | 12.30 | 3 | 0.24 | |
| 0.8...0.9 | 10.80 | 2.2 | 12.38 | 3.5 | 0.32 | |
| 1...1.125 | 11.09 | 3 | 12.46 | 4 | 0.40 | |
| 1.25...1.375 | 11.18 | 3.3 | 12.56 | 4.5 | 0.50 | |
| 1.5...1.75 | 11.53 | 4.2 | 12.66 | 5.5 | 0.60 | |
| 2...2.25 | 11.93 | 5.3 | 12.86 | 6 | 0.80 | |
| 2.5 | 12.18 | 6 | 13.06 | 6 | 1 | |