

Cutite de rabotat roti dintate conice tip IV Tapered gear planing tools IV type

STAS 6985\2-84

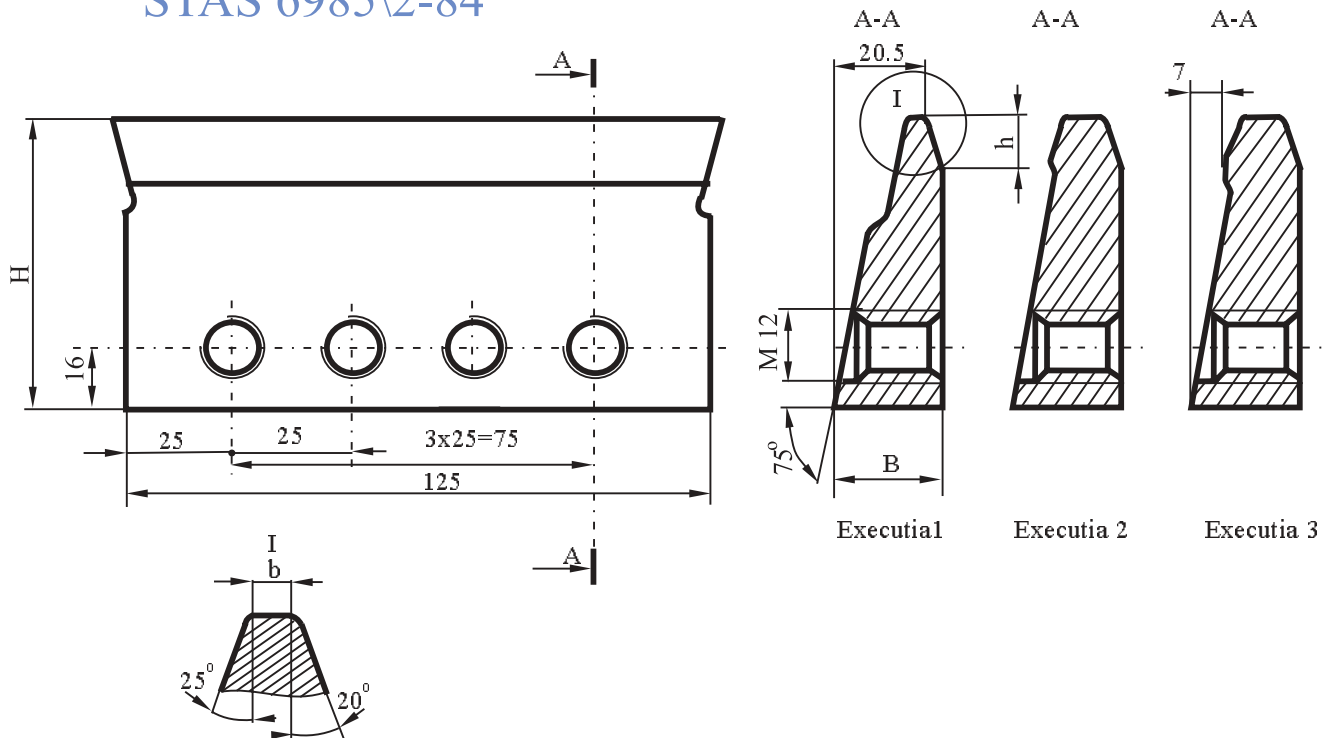

Modul mm	Executia	B mm	H mm	h mm	b mm	Pret ()
1	2	3	4	5	6	7
3	1	23.27	60	7.6	1.2	
3.25	1	23.27	60	7.6	1.2	
3.5	1	23.70	60	8.8	1.4	
3.75	1	23.70	60	8.8	1.4	
4	1	24.36	60	10.6	1.6	
4.25	1	24.36	60	10.6	1.6	
4.5	1	24.36	60	10.6	1.6	
5	1	25.23	60	13	2	
5.5	1	25.23	60	13	2	
6	1	26.14	60	15.5	2.4	
6.5	1	26.14	60	15.5	2.4	
7	1	26.51	60	16.5	2.8	
8	2	27.42	60	19	3.2	
9	2	28.33	60	21	3.6	
10	2	29.24	60	24	4	
11	2	29.89	60	25.8	4.4	
12	2	30.73	60	28.1	4.8	
14	3	32.44	75	32.8	5.6	
16	3	34.15	75	37.5	6.4	
18	3	35.86	75	42.2	7.2	
20	3	37.61	75	47	8	