

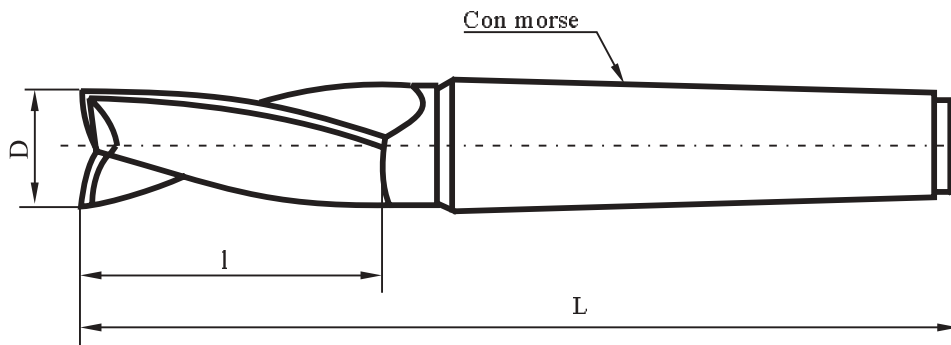

Freze pentru canelat cu coada conica Slotting milling cutters with taper shank

STAS 1681-85



D mm	L mm	l mm	CM mm	Pret ()
1	2	3	4	5
6	83	13	1	
7	86	16	1	
8	89	19	1	
9	89	19	1	
10	92	22	1	
11	92	22	1	
12	96	26	1	
14	96	26	1	
16	117	32	2	
18	117	32	2	
20	123	38	2	
22	123	38	2	
25	147	45	3	
28	147	45	3	
32	155	53	3	
36	155	53	3	
40	188	63	4	
45	188	63	4	
50	200	75	4	
56	200	75	4	
63	248	90	5	