

Freze cilindro-frontala cu coada conica End mill cutter with taper shank

STAS 1683-80

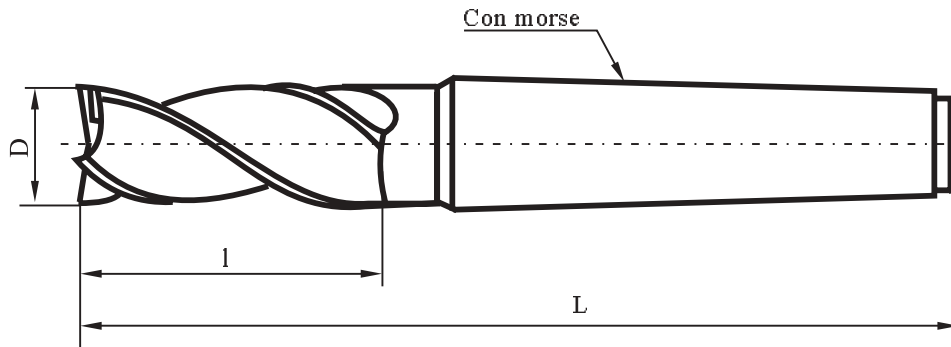

D mm	CM mm	Varianta normala		Varianta lunga		Nr. de dinti Z			Pret ()
		L mm	l mm	L mm	l mm	N	M	D	
1	2	3	4	5	6	7	8	9	10
6	1	83	13	94	24	4	3	4	
7	1	86	16	100	30	4	3	4	
8	1	89	19	108	38	4	3	5	
9	1	89	19	108	38	4	3	5	
10	1	92	22	115	45	4	3	5	
11	1	92	22	115	45	4	3	5	
12	1	96	26	123	53	4	3	6	
12	2	111	26	138	53	4	3	6	
14	1	96	26	123	53	4	3	6	
14	2	111	26	138	53	4	3	6	
16	2	117	32	148	63	4	3	6	
18	2	117	32	148	63	4	3	6	
20	2	123	38	160	75	4	3	6	
20	3	140	38	177	75	4	3	6	
22	2	123	38	160	75	5	3	8	
22	3	140	38	177	75	5	3	8	
25	3	147	45	192	90	5	3	8	
28	3	147	45	192	90	5	3	10	
32	3	155	53	208	106	6	4	10	
32	4	178	53	231	106	6	4	10	
36	3	155	53	208	106	6	4	10	
36	4	178	53	231	106	6	4	10	
40	4	188	63	250	125	6	4	10	
40	5	221	63	283	125	6	4	10	
45	4	188	63	250	125	6	5	12	
45	5	221	63	283	125	6	5	12	
50	4	200	75	275	150	8	5	12	
50	5	233	75	308	150	8	5	12	
56	4	200	75	275	150	8	5	12	
56	5	233	75	308	150	8	5	12	
63	5	248	90	338	180	8	6	14	