

## Freze disc detalonate pentru canale Slotting backed off cutters

STAS 2214-75

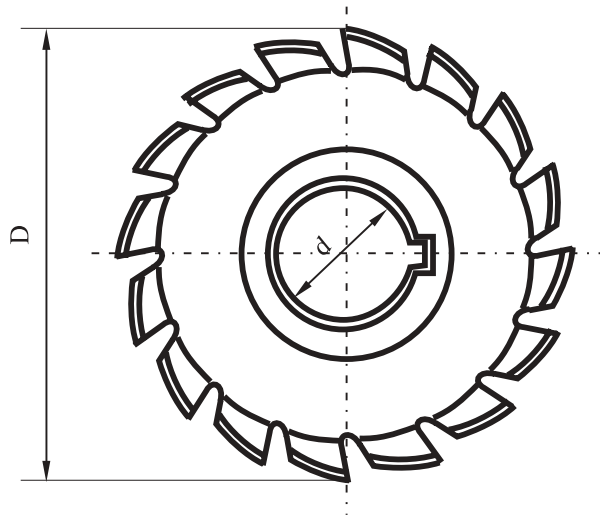
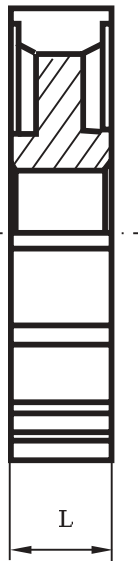

D mm	L mm	d mm	Nr. de dinti z	Pret ( )
1	2	3	4	5
50	4; 5; 6; 7; 8; 10;	16	10	
63	4; 5; 6; 7; 8; 9; 10; 12; 14;	22	10	
80	5; 6; 7; 8; 10; 12; 14; 16; 18;	27	12	
100	6; 7; 8; 10; 12; 14; 16; 18; 20; 22; 25;	32	14	
125	8; 10; 12; 14; 16; 18; 20; 22; 25;	32	16	
160	10; 12; 14; 16; 18; 20; 22; 25; 28; 32;	40	18	
200	12; 14; 16; 18; 20; 22; 25; 28; 32; 36; 40;	40	20	
250	14; 16; 18; 20; 22; 25; 28; 32; 36; 40; 45;	50	22	