

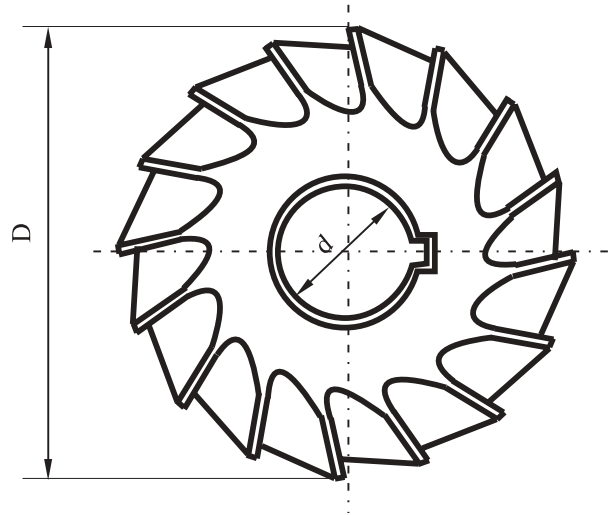

Freza unghiulara biconica
Double angle milling cutter

STAS 3542-80

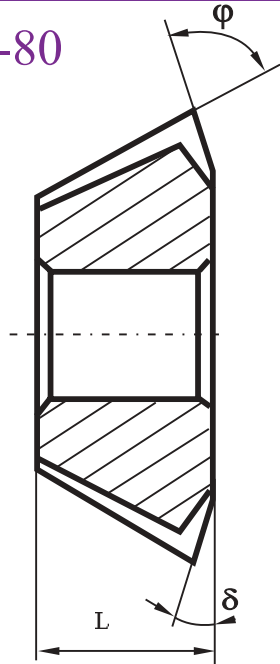

D mm	L mm	ϕ°	δ°	d mm	Nr. de dinti z	Pret ()
1	2	3	4	5	6	7
40	6	55; 60; 65	15	13	16	
40	8	70; 75	15	13	16	
40	10	80; 90	15; 20	13	16	
40	12	100	25	13	16	
50	8	55; 60	15	16	18	
50	10	65; 70; 75	15	16	18	
50	12	80	15	16	18	
50	16	90; 100	20; 25	16	18	
63	10	55; 60; 65	15	22	20	
63	12	70; 75	15	22	20	
63	16	80	15	22	20	
63	20	90; 100	20; 25	22	20	
80	12	50; 55; 60	15	22	22	
80	16	65; 70	15	22	22	
80	20	75; 80	15	22	22	
80	25	90	20	22	22	
100	25	65; 70	15	27	24	
100	32	75; 80	15	27	24	