

Freze unghiulare simetrice
Double equal angle milling cutter

STAS 5651-79

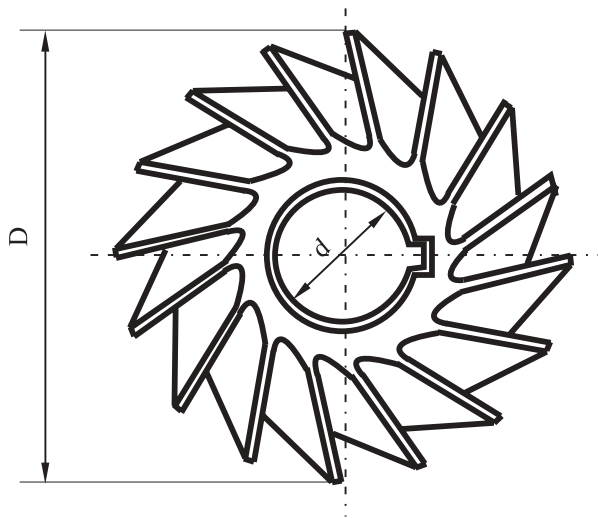
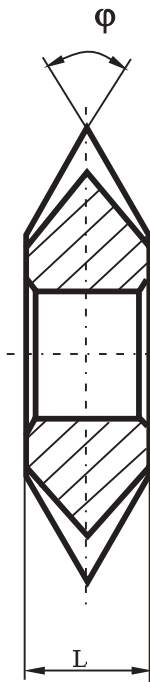

D mm	L mm	φ°	d mm	Nr. de dinti z	Pret ()
1	2	3	4	5	6
50	8	45	16	18	
50	10	60	16	18	
50	14	90	16	18	
63	10	45	22	20	
63	14	60	22	20	
63	20	90	22	20	
80	12	45	27	22	
80	18	60	27	22	
80	22	90	27	22	
100	18	45	32	24	
100	25	60	32	24	
100	32	90	32	24	