

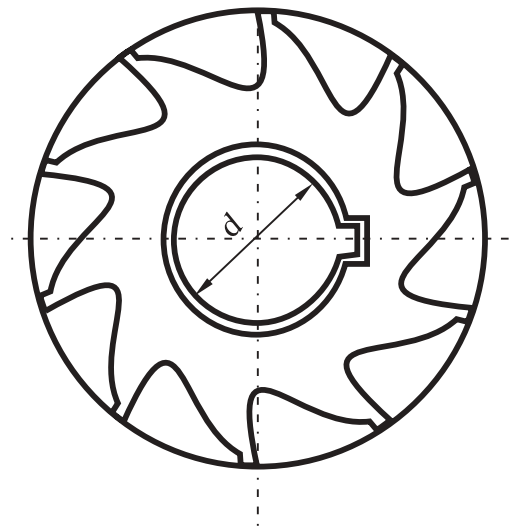

## Freze cilindrice Cylindrical cutters with plain bore and key drive

STAS 578-76

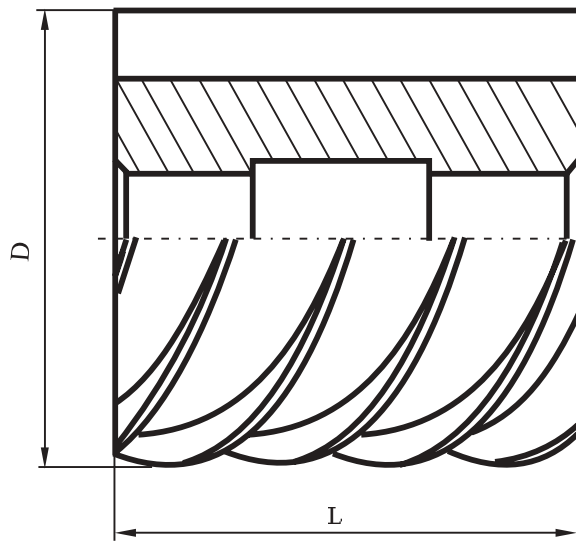

D mm	L mm	d mm	Tip N	Nr. de dinti z		Pret ( )
				Tip D	Tip M	
1	2	3	4	5	6	7
50	40	22	8	12	5	
50	63	22	8	12	5	
50	80	22	8	12	5	
63	50	27	8	14	6	
63	70	27	8	14	6	
80	63	32	10	16	6	
80	100	32	10	16	6	
100	70	40	10	18	8	
100	125	40	10	18	8	