

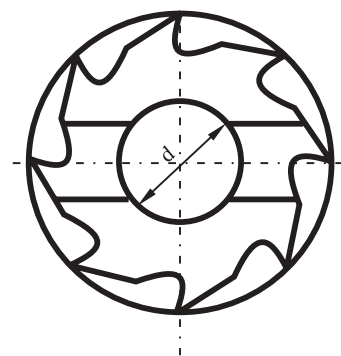

Freze cilindro-frontale  
Shell end mills with plain bore and tenon drive

STAS 579-76

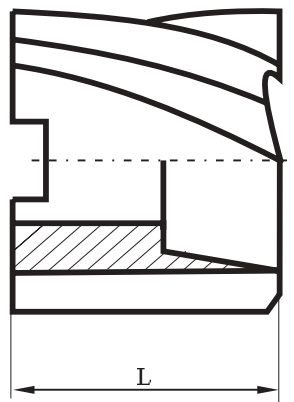
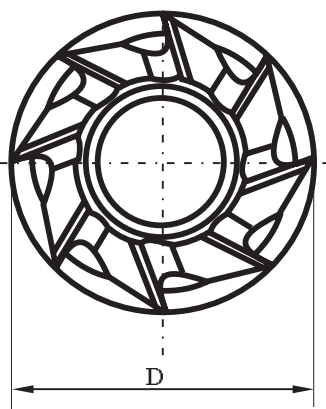

D mm	L mm	d mm	Tip N	Nr. de dinti z		Pret ( )
				Tip D	Tip M	
1	2	3	4	5	6	7
40	32	16	6	10	4	
50	36	22	8	12	5	
63	40	27	8	14	6	
80	45	27	10	16	6	
100	50	32	10	18	8	
125	56	40	12	22	8	
160	63	50	14	24	10	